

DOUBLE CHAINSTITCH

VC008

- 04

64 - 254

P / VSF

针数
Needle numbers

等距针距
Equal distance between needles

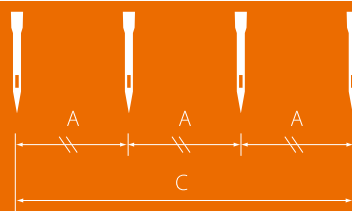

不等距
Unequal distance between needles

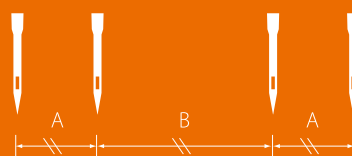

配件
Device

后拉引滚轮
Rear pullers

机种别 Model

VC008 多针机
Multineedle cylinder bed double chainstitch machine

HF008 牛仔上腰机平车
Four needle flat bed double chainstitch machine

VC008 SERIES FEATURES

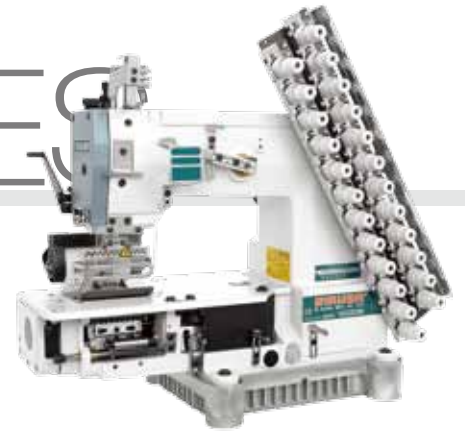

全自动供油 · 勾针纵向运动机构 · 多针双重链式缝

Automatic lubrication system, vertical looper mechanism, multineedle chainstitch mechanism.



采用独立勾针座 · 可变化不同的针位组合 · 达到一机多用的功能 (选配)

Using independent looper holder and can easily change different needle position, Multi-function machine design.(optional)



筒型机身设计 · 方便环型衣物缝纫

Cylinder machine frame design, easy sewing operation for circular cloth.



按钮式缝距调整模式 · 调整简便快速

Stitch length adjustment by knob, easy and fast.





左侧附一辅助设计 · 拉布稳定 · 出布更顺畅 · 维护便利

Using one supportive puller on left side which can stabilize the pulling and sewing process.

适用于多种工序的缝纫 · 适合针织类高级衣物之装饰车缝





Suitable for multi sewing process, high quality knit material and decorative sewing.

V1

Model	Specification	 		图释 (每格宽度 =3.2mm=1/8")																										Remark		
				1	2	3	4	5	6	7	8	9	10	11	12	13	14	15	16	17	18	19	20	21	22	23	24	25	26			
VC008-	04064P	4	8	1/4"(6.4mm)																												
	04085P			1/3"(8.5mm)																												
	04095P			3/8"(9.5mm)																												
	04106P			5/12"(10.6mm)																												
	04127P			1/2"(12.7mm)																												
	0448-191P			3/16-3/4-3/16" (4.8-19.1-4.8mm)																												
	0448-222P			3/16-7/8-3/16" (4.8-22.2-4.8mm)																												
	0448-254P			3/16-1-3/16" (4.8-25.4-4.8mm)																												
	0464-191P			1/4-3/4-1/4" (6.4-19.1-6.4mm)																												
	0464-127P			1/4-1/2-1/4" (6.4-12.7-6.4mm)																												
	0464-254P			1/4-1-1/4" (6.4-25.4-6.4mm)																												
	04A32-032P			(1/4-1/8-1/8-1/4")*3 (6.4-3.2-3.2-6.4mm)*3	6	12																										A
	04A64P			1/4"(6.4mm)																												
	12A32-032P			(1/4-1/8-1/8-1/4")*3 (6.4-3.2-3.2-6.4mm)*3	6	12																										B
12A64P	1/4"(6.4mm)																															
12048P	3/16"(4.8mm)	12	24																													
12064P	1/4"(6.4mm)																															
12050P	1/5"(5.0mm)																															
13032P	1/8"(3.2mm)																															
13064P	1/4"(6.4mm)																														C	
1332-032P	(1/4-1/8-1/8-1/4")*3 (6.4-3.2-3.2-6.4mm)*3																															
17032P	1/8"(3.2mm)																														D	
21032P	1/8"(3.2mm)																														E	
23032P	1/8"(3.2mm)																														F	

A: 13 针规格组, 配 4 组针 / 勾针
 B: 13 针规格组, 配 6 组针 / 勾针
 C: 13 针规格组, 配 13 组针 / 勾针
 D: 17 针规格组, 配 17 组针 / 勾针
 E: 21 针规格组, 配 21 组针 / 勾针
 F: 23 针规格组, 配 23 组针 / 勾针

A: 13-Needle gauge set with 4 sets of needle/ looper.
 B: 13-Needle gauge set with 6 sets of needle/ looper.
 C: 13-Needle gauge set with 13 sets of needle/ looper.
 D: 17-Needle gauge set with 17 sets of needle/ looper.
 E: 21-Needle gauge set with 21 sets of needle/ looper.
 F: 23-Needle gauge set with 23 sets of needle/ looper.

	1.4-3.6		12		UOX113GS #11~#14		4500
--	---------	---	----	---	---------------------	---	------

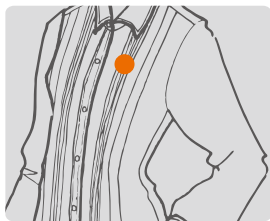

一般平缝

完全自动给油·勾针纵向运动机构·筒型车台·利于圆筒型衣物之缝纫·适用于一般高级衣物之装饰车缝

GENERAL SEAMING

Cylinder bed automatic oiling, back and forth loopers driving mechanism, suitable for decorative sewing on high quality dress or tubular goods.









4針機型
4-Needle type
VC008-04XXX
VC008-04XXX-XXX



12針機型
12-Needle type
VC008-12XXX
VC008-12XXX-XXX
VC008-13XXX
VC008-13XXX-XXX
VC008-17XXX
VC008-21XXX

V2

Model	Specification					2.5-5		12		UOX113GS #11~#14		4500	Remark																			
														图释 (每格宽度=3.2mm=1/8")																		
						1	2	3	4	5	6	7	8	9	10	11	12	13	14	15	16	17	18	19	20	21	22	23	24	25	26	
VC008-	1132-064P	11	22	(1/8-1/4-1/8") (3.2-6.4-3.2mm)																												





VC008-1132-064P

裤头车缝

本机型可以弹性组合出各种常用的4针针位组
如1/4-1/4-1/4, 1/4-3/4-1/4...等

WAIST BAND SEWING

This model offers various 4-needle gauge combinations by one gauge set.
E.g.: 1/4-1/4-1/4, 1/4-3/4-1/4...etc.

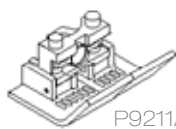



	VCL08S	Fine teeth type upper puller (steel) 細齒上拉輪 (鋼質)
	VCL16P	Flat type puller set (PU) 平輪組 (PU 材質)
	VCL28	
	P9211A-A	Two-piece type presser foot (for waist banding) 二段式押腳 (褲頭專用)

> 选购 OPTION

配件	DEVICE
	VCE



V3

							
	4	8	1/4"(6.4mm)	1.4-3.6	12	UOX113GS #11~#14	4500
VC008-04064P/VCE	4	8	1/4"(6.4mm)	1.4-3.6	12	UOX113GS #11~#14	4500
VC008-04085P/VCE	4	8	1/3"(8.5mm)	1.4-3.6	12	UOX113GS #11~#14	4500
VC008-04095P/VCE	4	8	3/8"(9.5mm)	1.4-3.6	12	UOX113GS #11~#14	4500
VC008-04106P/VCE	4	8	5/12"(10.6mm)	1.4-3.6	12	UOX113GS #11~#14	4500
VC008-04127P/VCE	4	8	1/2"(12.7mm)	1.4-3.6	12	UOX113GS #11~#14	4500



VC008-04095P/VCE

裤头松紧带车缝

用于运动裤或运动短裤等圆筒型衣裤腰部松紧带的包缝。本机型可有两种缝合的方式:

- (1)环型松紧带布料折边缝
- (2)拷克后上环形松紧带包缝

ELASTIC INSERTING / ATTACHING

Inserting and attaching elastic on waistband of jogging suits, sportswear or shirts etc., two types of sewing functions are available :

- 1. To attach tubular seamless elastic waistband.
- 2. To cover sewing on elastic after overlock seaming.

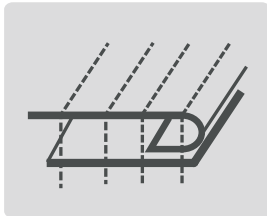
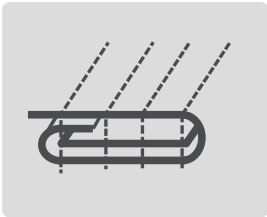

> 选购 OPTION

配件 DEVICE
VAD , VUT , RL

	4	8	1/4"(6.4mm)	1.4-3.6	12	UOX113GS #11~#14	4000
VC008-04064P/VWL	4	8	1/3"(8.5mm)	1.4-3.6	12	UOX113GS #11~#14	4000
VC008-04085P/VWL	4	8	3/8"(9.5mm)	1.4-3.6	12	UOX113GS #11~#14	4000
VC008-04106P/VWL	4	8	5/12"(10.6mm)	1.4-3.6	12	UOX113GS #11~#14	4000
VC008-04127P/VWL	4	8	1/2"(12.7mm)	1.4-3.6	12	UOX113GS #11~#14	4000



VC008-04085P/VWL

裤头松紧带车缝 (附B413喇叭)

松紧带送带滚轮装置能依据机台之运转速度送带，可准确控制松紧带长度与松紧度，操作简便，适用于慢跑裤、运动裤、男女内裤等裤头之松紧带车缝

注：B413喇叭可用松紧带尺寸为 38mm

ELASTIC ATTACHING (WITH BINDER B413)

Elasticity and length feeding can be accurately controlled according to sewing speed of machine. Easy operation for elastic inserting and attaching on waistband of jogging pants, sportswear, briefs etc.

Remark : Elastic size 38mm for binder B413

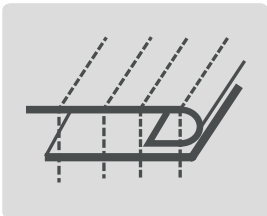

> 选购 OPTION

配件 DEVICE
FH

V5

							
	4	8	→ ←	mm	mm	Needle No.	S.P.M. (Max)
VC008-04064P/VWLB	4	8	1/4"(6.4mm)	1.4-3.6	12	UOX113GS #11-#14	4000
VC008-04085P/VWLB	4	8	1/3"(8.5mm)	1.4-3.6	12	UOX113GS #11-#14	4000
VC008-04095P/VWLB	4	8	3/8"(9.5mm)	1.4-3.6	12	UOX113GS #11-#14	4000
VC008-04106P/VWLB	4	8	5/12"(10.6mm)	1.4-3.6	12	UOX113GS #11-#14	4000
VC008-04127P/VWLB	4	8	1/2"(12.7mm)	1.4-3.6	12	UOX113GS #11-#14	4000



VC008-04085P/VWLB

裤头松紧带车缝 (附B411喇叭及撑开滚轮组)

松紧带送带滚轮装置能依据机台之运转速度送带，可准确控制松紧带长度与松紧度，操作简便，适用于慢跑裤、运动裤、男女内裤等裤头之松紧带车缝

ELASTIC INSERTING (WITH BINDER B411 AND EXTENDING ROLLER)

Elasticity and length feeding can be accurately controlled according to sewing speed of machine. Easy operation for elastic inserting and attaching on waistband of jogging pants, sportswear, briefs etc.

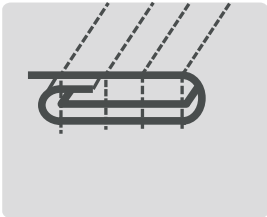

> 选购 OPTION

配件	DEVICE
	FH

喇叭尺寸 BINDER SIZE	成品尺寸 FINISHED SIZE	松紧带尺寸 ELASTIC TAPE SIZE	适用机型 APPLICABLE MODEL
B411	33 mm	31 mm	04095
B411P	30 mm	28 mm	04085
B411Q	42 mm	40 mm	04127
B411R	25 mm	23 mm	04064
B411S	36 mm	34 mm	04106

V6



	4	8	1/4"(6.4mm)	1.4-3.6	12	UOX113GS #11~#14	4000
VC008-04064P/VWLC	4	8	1/3"(8.5mm)	1.4-3.6	12	UOX113GS #11~#14	4000
VC008-04085P/VWLC	4	8	3/8"(9.5mm)	1.4-3.6	12	UOX113GS #11~#14	4000
VC008-04106P/VWLC	4	8	5/12"(10.6mm)	1.4-3.6	12	UOX113GS #11~#14	4000
VC008-04127P/VWLC	4	8	1/2"(12.7mm)	1.4-3.6	12	UOX113GS #11~#14	4000
VC008-12048P/VWLC	12	24	3/16"(4.8mm)	1.4-3.6	12	UOX113GS #11~#14	4000
VC008-12064P/VWLC	12	24	1/4"(6.4mm)	1.4-3.6	12	UOX113GS #11~#14	4000



VC008-04085P/VWLC

裤头松紧带车缝 (附VCE导片)

松紧带送料滚轮装置能依据机台之运转速度送料，可准确控制松紧带长度与松紧度，操作简便，适用于慢跑裤、运动裤、男女内裤等裤头之松紧带车缝

ELASTIC INSERTING /ATTACHING (WITH VCE FABRIC GUIDE)

Elasticity and length feeding can be accurately controlled according to sewing speed of machine. Easy operation for elastic inserting and attaching on waistband of jogging pants, sportswear, briefs etc.

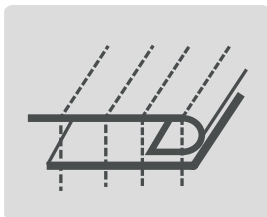
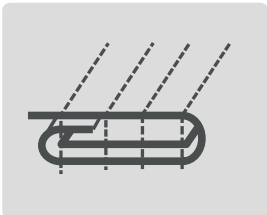

> 选购 OPTION

配件 DEVICE
FH

V7

VC008-02064P/VMR	2	4	1/4"(6.4mm)	1.4-3.6	12	UOX113GS #11~#14	1000



VC008-02064P/VMR

摺景车缝(规则波浪式)

由六种花盘变化·可缝製7种不同花样之摺景·适用于高级衣饰、窗帘、床罩等寝具的装饰缝及桌巾或室内装饰品之打摺缝

RUFFLING (REGULAR WAVY TRUCK)

For ruffling sewing on blouses, curtains, bed sheets, tablecloths or decorating cloth etc., six different kinds of cam variations available to obtain various ruffling designs.

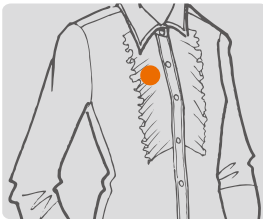
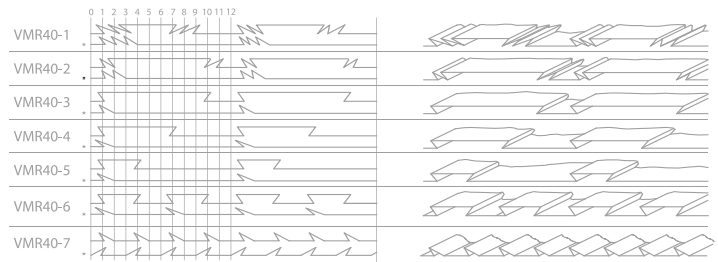

V8

VC008-06048P/VPL	6	12	3/16"(4.8mm)	1.4-3.6	12	UOX113GS #11~#14	4000
VC008-06064P/VPL	6	12	1/4"(6.4mm)	1.4-3.6	12	UOX113GS #11~#14	4000



VC008-06064P/VPL

上带车缝

适用于装饰条带、运动衣裤等车缝·效率高、品质稳定

TAPE ATTACHING

Suitable for attaching ornament tape on sportswear. For high efficiency and perfect quality sewing.

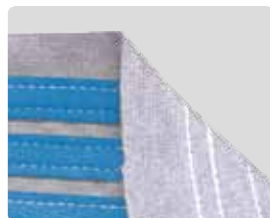
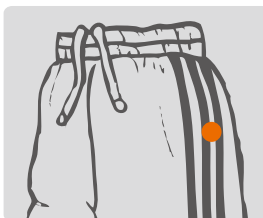

> 选购 OPTION

配件 DEVICE
LS-A

VC008-12048P/VPQ	12	24	3/16"(4.8mm)	1.4-3.6	12	UOX113GS #11~#14	4000
VC008-12064P/VPQ	12	24	1/4"(6.4mm)	1.4-3.6	12	UOX113GS #11~#14	4000



VC008-12064P/VPQ

松紧带抽皱缝装置





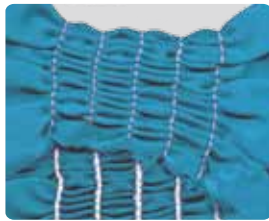
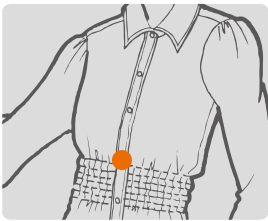

适用于女皱摺连身衣裙等腰边松紧线皱摺·如女用衬衫、游泳衣、枕头套、儿童衫等均能车缝顺畅
注：勾针底线宜用伸缩松紧带线(橡皮线)

ELASTIC THREAD SHIRRING SEWING

Suitable for sewing ornamental shirring with elastic thread on ladies' blouses, swimsuits, dresses, pillowcases, and childrens' shirts etc.
Remark : Suggested to use elastic thread for lower looper



V10

							Needle No.	
VC008-12048P/VPQ-K	12	24	3/16"(4.8mm)	1.4-3.6	12	UOX113GS #11~#14	4000	
VC008-12064P/VPQ-K	12	24	1/4"(6.4mm)	1.4-3.6	12	UOX113GS #11~#14	4000	

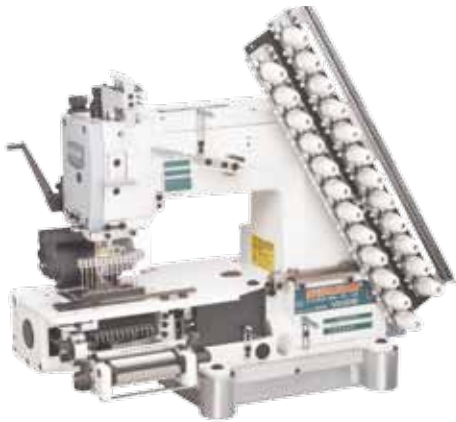

VC008-12048P/VPQ-K

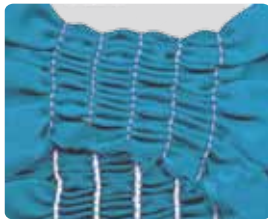
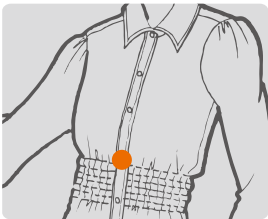

松紧带抽皱缝装置

适用于女皱摺连身衣裙等腰边松紧线皱摺·如女用衬衫·游泳衣·枕头套·儿童衫等均能车缝顺畅

注:

1. 勾针底线宜用伸缩松紧带线(橡皮线)
2. 增加VWL组可稳定松紧线的松紧度让车缝更平顺美观·不跳针
3. 将松紧线安装于桌板下·让松紧线车缝更顺畅
4. 本机为多功能车·可调为VWL·VPQ或一般车使用

ELASTIC THREAD SHIRRING SEWING

Suitable for sewing ornamental shirring with elastic thread on ladies' blouses, swimsuits, dresses, pillowcases, and childrens' shirts etc.

Remark :

1. Suggested to use elastic thread for lower looper.
2. The added VWL set will further stabilize the tension of elastic thread and make sewing process more smoothly, also can avoid stitch skipping.
3. Holds the elastic thread under the table to make sewing process more smoothly.
4. This is a multifunctional machine, can easily adjust to VWL, VPQ, or standard machine.

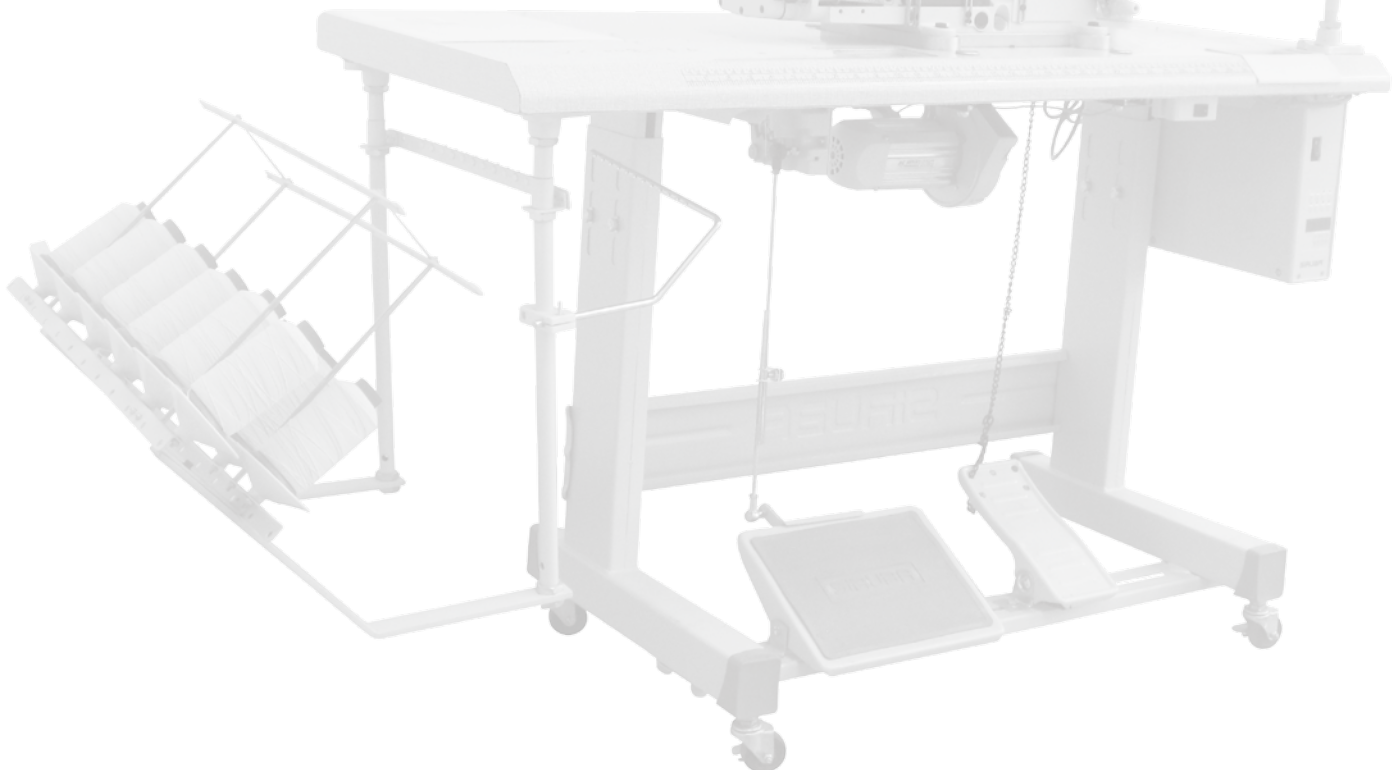
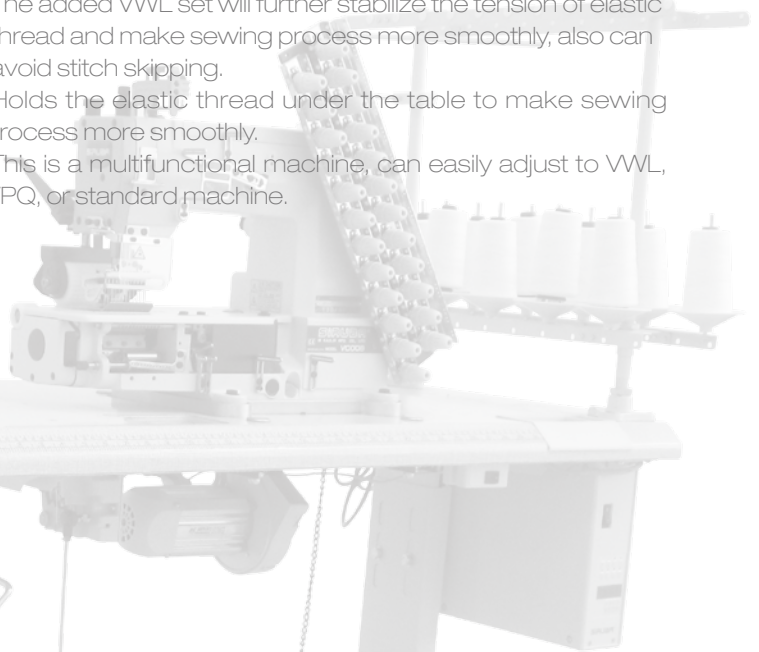

V11



VC008-12048P/VPS	12	12	3/16"(4.8mm)	1.4-3.6	12	DV-K25 #18~21	4000
VC008-12064P/VPS	12	12	1/4"(6.4mm)	1.4-3.6	12	DV-K25 #18~21	4000



VC008-12064P/VPS

松紧带抽皱缝装置

适用于女皱折连身衣裙等腰边松紧线皱折，如女用衬衫、游泳衣、枕头套、儿童衫等均能车缝顺畅

注:针线用伸缩松紧带线(橡皮线)，以勾针为勾线功能不穿线，为101车缝式样

ELASTIC THREAD SHIRRING SEWING

Suitable for sewing ornamental shirring with elastic thread on ladies' blouses, swimsuits, dresses, pillowcases, and childrens' shirts etc.

Remark: Needle uses elastic thread and looper without thread. It's 101 sewing type.

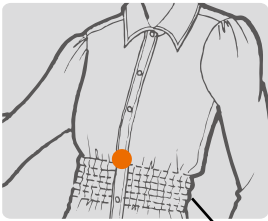

V12



VC008-12048P/VPT	12	24	3.16"(4.8mm)	1.4-3.6	12	UOX113GS #11~#14	2500
VC008-12064P/VPT	12	24	1/4"(6.4mm)	1.4-3.6	12	UOX113GS #11~#14	2500



VC008-12064P/VPT

褶布车缝





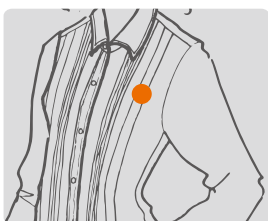
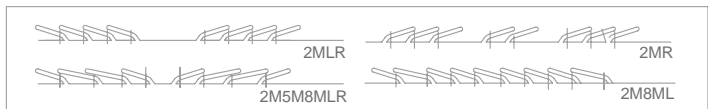

可自由多种调整导边器之组合，车缝成各种不同式样之右倾或左倾褶缝，如衬衫、连衣裙、儿童衫等细条打褶用

PIN TUCKING

Suitable for pin-tuck sewing on men's, ladies', and children's shirt, dress, etc. Attachment is freely adjustable in various sewing style of left or right side folding.



V13

							
VC008-0448-254P/VSF	4	8	3/16-1-3/16" (4.8-25.4-4.8mm)	1.4-3.6	12	UOX113GS #11~#14	4000
VC008-0464-191P/VSF	4	8	1/4-3/4-1/4" (6.4-19.1-6.4mm)	1.4-3.6	12	UOX113GS #11~#14	4000
VC008-0464-254P/VSF	4	8	1/4-1-1/4" (6.4-25.4-6.4mm)	1.4-3.6	12	UOX113GS #11~#14	4000



VC008-0464-254P/VSF

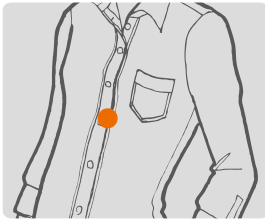

衬衫门襟车缝

适宜各种四针或二针之衬衫门襟车缝，由于加装喇叭使在一个工序即可完成车缝，另可选择不同的喇叭做不同之车缝样式







SHIRT-FRONTING ATTACHING

With a special folder to sew on 2 or 4 needled shirt fronting, complete in one simple sewing operation. Also available are the various folders for different sewing style.

> 选购 OPTION

配件 DEVICE
LS-A

V14

							
VC008-12048P/VSM	12	24	3/16"(4.8mm)	1.4-3.6	12	DVX57 #18~#21	2000
VC008-12064P/VSM	12	24	1/4"(6.4mm)	1.4-3.6	12	DVX57 #18~#21	2000



VC008-12048P/VSM

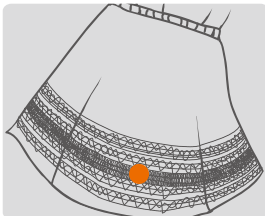

花饰缝

由十六个花盘变化，利用针线之搭配，可缝製数十种不同花样，适用于高级衣饰、窗帘、床罩等寝具的装饰缝及桌巾或室内装饰品之花饰缝

DECORATIVE SEWING

To use sixteen different cams of variation for different sewing, suitable for decorative sewing on high quality dresses, curtains, bed sheets and tablecloths.

V15



VC008-12048P/VSQ	12	24	3/16"(4.8mm)	1.4-3.6	12	DV-K25 #18	2000
VC008-12064P/VSQ	12	24	1/4"(6.4mm)	1.4-3.6	12	DV-K25 #18	2000



VC008-12048P/VSQ

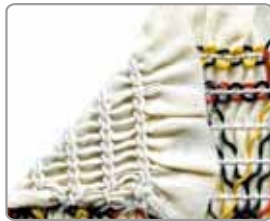
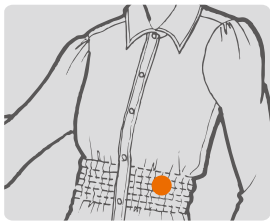

松紧抽皱花饰缝

由16种花盘变化·利用松紧针线之搭配·可缝製数十种不同花样·适用于高级衣饰·窗帘·床罩等寝具的装饰缝及桌巾或室内装饰品之花饰缝

DECORATIVE SEWING WITH ELASTIC THREAD SHIRRING

To use sixteen different cams of variation for different sewing, suitable for decorative sewing on high quality dresses, curtains, bed sheets, tablecloths.

V16



VC008-12048P/VSC	12	36	3/16"(4.8mm)	1.4-3.6	12	UOX113GS #11~#14	2500
VC008-12064P/VSC	12	36	1/4"(6.4mm)	1.4-3.6	12	UOX113GS #11~#14	2500



VC008-12064P/VSC

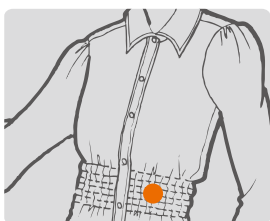

松紧带抽皱缝装置







伸缩松紧带线(橡皮线)直送不打线圈·由针线与勾针线上下包覆·车缝成品效果较VPQ薄·且皱折可拉伸至完全平坦

ELASTIC THREAD SHIRRING SEWING

Elastic thread is straight, not looped, which is fixed by needle thread and looper thread. The finish is thinner than VPQ and the shirring becomes flat as it is pulled extensively.



V17

							
	12	24	3/16"(4.8mm)	1.4-3.6	12	DVX57 #18-#21	2000
VC008-12048P/VSSM	12	24	3/16"(4.8mm)	1.4-3.6	12	DVX57 #18-#21	2000
VC008-12064P/VSSM	12	24	1/4"(6.4mm)	1.4-3.6	12	DVX57 #18-#21	2000



VC008-12048P/VSSM

花饰缝

由十六个花盘变化·利用针线之搭配·可缝製数十种不同花样·适用于高级衣饰、窗帘、床罩等寝具的装饰缝及桌巾或室内装饰品之花饰缝

DECORATIVE SEWING

To use sixteen different cams of variation for different sewing, suitable for decorative sewing on high quality dresses, curtains, bed sheets and tablecloths.

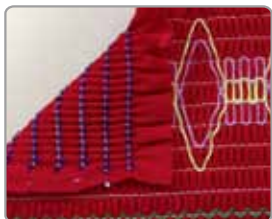
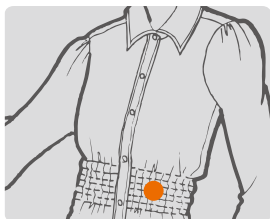

机型 Model	品名 Name	备注 Remark
VC008-25/33P	25/33 针, 双线链式缝缝纫车 25/33 needle, double chainstitch machine	后拉滚轮, 一般缝纫 Rear puller, general seaming.
VC008-PQ2(1/4)	25/33/38/50 针, 松紧线缩褶车 25/33/38/50 needle, shirring stitch machine	上线普通, 下线橡筋, 加前轮 The upper thread is the general thread, the lower thread is the elastic thread, the front wheel is attached.
VC008-PQ3(1/4)	25/33/38/50 针, 松紧线缩褶车 25/33/38/50 needle, shirring stitch machine	上线普通, 下线普通, 布的下面包橡筋 The upper thread is the general thread, the lower thread is the general thread, the elastic thread is underneath the cloth.
VC008-PQ3M(1/4)	16/25/33/38/50 针, 松紧线缩褶打揽车 16/25/33/38/50 needle, shirring smocking stitch machine	上线普通, 下线普通, 布的下面包橡筋, 打揽 The upper thread is the general thread, the lower thread is the general thread, the elastic is underneath the cloth, smocking.
VC008-PQS(1/4)	25/33/38/50 针, 松紧线 (无底线) 多针车 25/33/38/50 needle, no lower thread shirring stitch machine	无底线 No lower thread.
VC008-PQSM(1/4)	25/33/38/50 针, 无底线打揽车 25/33/38/50 needle, no lower thread smocking machine	无底线, 打揽 No lower thread, smocking.
VC008-PSM/PTV(1/4)	25/33 针, 打揽打褶综合车 25/33 needle, smocking pintucking machine	打折 (25 条) 可打折宽度 1-2mm Pintucking (25 lines), the width of pintucking is 1~2mm.
VC008-PSM/PL(1/4)	25/33/38/50 针, 打揽贴条综合车 25/33/38/50 needle, smocking tape-attaching machine	上下普通线打揽, 同时加运动贴条 The upper thread is the general thread, the lower thread is general thread, smocking the tape is attached simultaneously.
VC008-PSM (1/4)	25/33/38/50 针, 装饰线打揽车 25/33/38/50 needle, ornamental thread smocking machine	上线普通, 下线普通, 打揽 The upper thread is the general thread, the lower thread is the general thread, smocking.
VC008-PSSM(1/4)	16/25/33 针, 松紧线缩褶打揽车 16/25/33 needle, shirring smocking stitch machine	上线普通, 下线橡筋, 打揽, 加前轮 The upper thread is the general thread, the lower thread is the elastic thread, smocking, the front wheel is attached.
VC008-PTV(1/4)	25/33 针, 衬衫打褶车 25/33 needle, shirts pintucking machine	打折 (25 条) 可打折宽度 1-2mm Pintucking (25 lines), the width of pintucking is 1~2mm.
VC008-PQT	25/33 针, 松紧线车 25/33 needle, shirring stitch machine	上线普通, 无底线, 布的下面包橡筋 The upper thread is the general thread, no lower thread, the elastic underneath the cloth.
VC008-PQTM	25/33 针, 打揽车 25/33 needle, smocking stitch machine	上线普通, 无底线, 布的下面包橡筋打揽 The upper thread is the general thread, no lower thread, the elastic underneath the cloth, smocking.

DEVICE

机型 Model	上线 Upper (Needle) Thread	下线 Lower (Looper) Thread	布下面包橡筋线 Extra Elastic Thread Under Fabric	前轮 Front Puller	打揽装置 Smocking Device	备注 Remark
P	普通 Cotton	普通 Cotton	--	--	--	
PQ2	普通 Cotton	橡筋 Elastic	--	有 Yes	--	
PQ2R	普通 Cotton	--	布上面 Upper Textile	有 Yes	有 Yes	
PQS	橡筋 Elastic	--	--	选配 Optional	--	粗橡筋线 Thick Elastic Thread
PQSM	橡筋 Elastic	--	--	选配 Optional	有 Yes	
PSM	普通 Cotton	普通 Cotton	--	--	有 Yes	
PSSM	普通 Cotton	橡筋 Elastic	--	有 Yes	有 Yes	
PQ3	普通 Cotton	普通 Cotton	有 Yes	有 Yes	--	
PQ3M	普通 Cotton	普通 Cotton	有 Yes	有 Yes	有 Yes	
PTV	普通 Cotton	普通 Cotton	--	--	--	打折装置 With Pin-tucking Device
PSM+PTV	普通 Cotton	普通 Cotton	--	--	有 Yes	打折装置 With Pin-tucking Device
PQT	普通 Cotton	--	有 Yes	有 Yes	--	
PQTM	普通 Cotton	--	有 Yes	有 Yes	有 Yes	

打 揽 机 花 盘 图 样

PATTERN OF CAMS

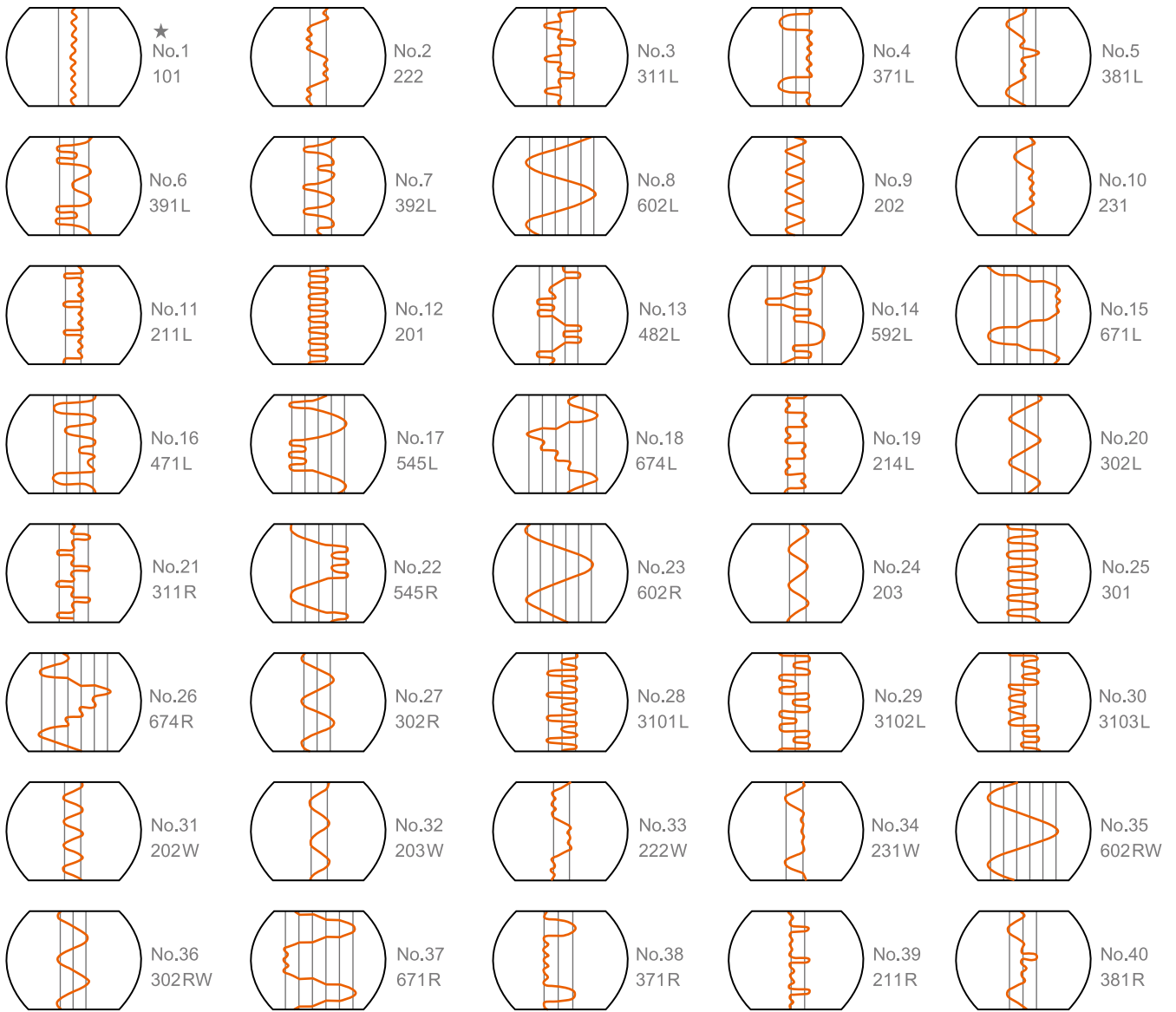

在更换使用花盘时·花盘编号后带“L”的为控制下面两层打揽条·应安装在靠机头的里面；花盘编号后带“R”的为控制上面两层打揽条·应安装在外面·切记不可倒装·否则编不出花型。另有花盘编号后带“W”的和“101”“202”“203”等花盘为里外皆可安装的。

When replacing the face plate, if the code of the face plate added on “L” means it controls the under two-layered smocking tape, so it should be installed inside and near the machine head. If the code of the face plate added on “R” means it controls the upper two-layered smocking tape, so it should be installed outside. Do not install two kinds of the face plates upside down, or it can't make the patterns. Besides, there are the codes of the face plate added on “W”, “101”, “202”, and “203”, which means they can be installed both inside and outside.



VCL(P) 后拉引滚轮 Rear Puller

协助车缝后平顺，不会挤压。与针位距离 72 mm,让拉布与出布更稳定

注: 各机型搭配平轮或齿轮如下表, 若有异于标准品订购时请特别注明

Smooths the sewing process, and no shirr. The 72 mm distance from the needle helps to stabilize the fabric during sewing process.

Remark: Please check the type of pullers (flat or serrated) used for different machines from the table below. If you would like to order different pullers standard, please remark when ordering other than.

滚轮 / Roller	平轮 / Flat		齿轮 / Gear	
上 / Upper	VCL16	VCL16P	VCL37(27T)	VCL37P(27T)
下 / Lower	VCL28	VCL28	VCL33P(16T)	VCL33P(16T)
VC008-04xxxP			S	
VC008-04xxxP/VCE			S	
VC008-02xxxP/VMR	S			
VC008-04xxxP/VSF	S			
VC008-04xxxP/VWL			S	
VC008-06xxxP/VPL		S		
VC008-12xxxP				S
VC008-12xxxP/VCE				S
VC008-12xxxP/VPQ		S		
VC008-12xxxP/VPT		S		
VC008-12xxxP/VWL				S
VC008-12xxxP/VPQ-K		S		
VC008-12xxxP/VSM		VCL16D		
VC008-12xxxP/VSQ		VCL16D		

VCL滚轮明细表 VCL Roller List

Type	平轮 Flat Type				齿轮 Gear Type		压花 Knurling	
材质 Material	硬质塑料 PU (White)		软质橡胶 Rubber (Black)		塑钢 POM (White)		钢质 Steel	
Length	Short	Long	Short	Long	Short	Long	Short	Long
上滚轮 Upper	VCL16	VCL16P	VCL16Q	VCL16R	VCL08(22T) 厚 Heavy	VCL08P(22T) 厚 Heavy	VCL08Q (59T)	VCL08N (22T)
					VCL37(27T) 中厚 Medium	VCL37P(27T) 中厚 Medium		
					VCL59(44T) 薄 Light	VCL60(44T) 薄 Light		
					VCL62(54T) 轻薄 Fine	VCL63(54T) 轻薄 Fine		
下滚轮 Lower	VCL28	VCL28R	VCL28R	VCL28R	VCL33(14T) 厚 Heavy	VCL33P(16T) 中厚 Medium	VCL33N(22T)	VCL33N(22T)
					VCL33P(16T) 中厚 Medium			
					VCL61(28T) 薄 Light			
					VCL64(32T) 轻薄 Fine			

滚轮选用原则 Puller Set Application

平轮 Flat type	塑料 PU	适用一般薄布料，如梭织棉布 For common materials, eq. woven cotton fabric.
	橡胶 Rubber	适用贴带车缝，或光滑薄布料使用，如梭织丝光布 For tap attaching or slippery materials, eq. woven silk fabric.
齿轮 Gear type	粗齿塑钢 Big-teeth POM	适用松紧带车缝，大折景 For elastic band sewing, big gathering
	细齿塑钢 Fine-teeth POM	适用松紧带车缝，小折景 For elastic band sewing, small gathering
钢质压花轮 Knurling Steel roller		适用牛仔类与厚布料 For jeans and heavy material

可自行组装 self-installation : NO

适用机型 applicable model : VC008



VMR

双针打折装置 Ruffling

适用于窗帘·床罩等寝具的装饰缝及桌布或室内装饰品之打折·由花盘(凸轮)控制可缝制各种各样漂亮的皱折

注:1.皱折最大间距 7-8 mm

2.六块花盘凸轮如V15附图

Decorative sewing on curtain and bed sheet or various ruffling patterns on table cloth or indoor decoration which controlled by cams.

Remark: 1. Maxium 7-8 mm space for shirring.

2. Six cams as listed on V15.

可自行组装 self-installation : NO

适用机型 applicable model : VC008-02064P



VPL

贴带装置 Tape Attaching

主要用于衬衫门襟·腰带·运动衣等装饰条带

注: 1.喇叭成品规格如图表

2.布条之尺寸可依3/16"或1/4"倍数变换

Decorative tape for shirt-fronting, sports wear, waist band, etc...

Remark: 1. Binder and finished goods specifications as listed in the table below

2. Type size can be adjusted in multiples of 3/16" or 1/4".

机型 Model	完成尺寸 Finished Size(mm)	X	Y	Z	针距 Needle Gauge	押具 Presser Foot
VC008-06048P	8	B417P	B417AP	B417P	3/16"	P9412DA
	9	B417Q	B417AQ	B417Q		P9412D
VC008-06064P	10	B417R	B417AR	B417R	1/4"	P9512DA
	12	B417S	B417AS	B417S		P9512D
VC008-12064P	16	B417U	B417AU	B417U	1/2"	P9512B
					1/4"	P9712D

可自行组装 self-installation : YES

适用机型 applicable model : VC008-06048P, VC008-06064P



VPQ

伸缩线抽折缝装置 Elastic Thread Shirring

适用于女用裙皱折·连身衣裙等腰边松紧带皱折均能顺畅缝纫·勾针底线宜用伸缩松紧带线

Suitable for sewing ornamental shirring on ladies' blouses. Suggested to use elastic thread for lower looper.

可自行组装 self-installation : YES

适用机型 applicable model : VC008-12048P, VC008-12064P



VPQ-K

伸缩线抽折缝装置 Elastic Thread Shirring

适用于女用裙皱折·连身衣裙等腰边松紧带皱折均能顺畅缝纫

1.勾针底线宜用伸缩松紧带线

2.增加VWL组可稳定松紧带的松紧度让车缝更平顺美观,不跳针

3.将松紧线安装于桌板下·让松紧线车缝更顺畅

4.本配件为多功能,可调为VWL·VPQ单一使用

Suitable for sewing ornamental shirring on ladies' blouses.

1. Suggested to use elastic thread for lower looper.
2. The added VWL set will further stabilize the tension of elastic thread and make sewing process more smoothly, also can avoid stitch skipping.
3. Holds the elastic thread under the table to make sewing process more smoothly.
4. Multifunction device can be adjusted to VWL or VPQ.

可自行组装 self-installation : YES

适用机型 applicable model : VC008-12048P, VC008-12064P



VPS

伸缩线抽折缝装置 Elastic Thread Shirring

适用于女用裙皱折·连身衣裙等腰边松紧带皱折·如：女衬衫·游泳衣,妇女用衣物·枕头套·儿童衫. 针线用伸缩松紧带线·勾针为勾线功能不穿线·为101车缝式样

Suitable for sewing ornamental shirring on ladies' blouses, swimsuits, pillowcase, children's shirts. Needle uses elastic thread and looper without any thread. It's 101 sewing type.

可自行组装 self-installation : YES

适用机型 applicable model : VC008-12048P, VC008-12064P



VPT

折布车缝装置(明折缝) Tucking (Visible Fold Seaming)(VPT) 折布车缝装置(暗折缝) Tucking (Blind Fold Seaming) (VPTA)

配合多种导边器可组合各种打折·右倾或左倾折均能完美之缝纫如：衬衫·连衣裙·衣服·儿童衬衫·尼龙裤等细条打折用

注：如购一般机型自行安装的VPT时·VA05及VA06导边器固定处需自行攻牙

Using various folders for different side shirring patterns, suitable for shirts, woman's dress, children's shirts, nylon pants.

REMARK: When installing VPT device on standard machine, position of VA05 and VA06 folder need to be tapped first.

可自行组装 self-installation : YES

适用机型 applicable model : VC008-12048P, VC008-12064P



VWL VWLB VWLC

前松紧带送带滚轮装置 Front Elastic Feeding

松紧带送带滚轮装置能随机台本身之运转·将松紧带送出,且可调整松紧带送出量之多寡·操作简便;车缝慢跑裤·运动裤·休闲裤等裤头·由于前后导轮装置·上松紧带时能保持一定张力,维持车缝品质

註: VWL附B413喇叭

VWLB附B411喇叭及撑开滚轮组

VWLC附VCE导片

Length of elastic type can be easily adjusted by elastic feeding device, suitable for sports pants and casual pants. Roller maintains the tension of elastic thread and quality during sewing process.

REMARK: VWL with binder B413

VWLB with binder B411 and extending roller

VWLC with VCE fabric guide

可自行组装 self-installation : YES

适用机型 applicable model : VC008-04064P, VC008-04085P, VC008-04095P,
VC008-04106P, VC008-04127P, VC008-12048P,
VC008-12064P

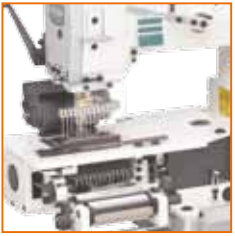

VSC

松紧带抽皱缝装置 Elastic Thread Shirring Sewing

伸缩松紧带线(橡皮线)直送不打线圈·由针线与勾针线上下包覆·车缝成品效果较VPQ薄·且皱折可拉伸至完全平坦

Elastic thread is straight, not looped, which is fixed by needle thread and looper thread. The finish is thinner than VPQ and the shirring becomes flat as it is pulled extensively.



可自行组装 self-installation : NO

适用机型 applicable model : VC008-12048P, VC008-12064P



VSF

门襟车缝装置 Shirt-Fronting

对于各种衬衫门襟用四针或二针,因有专用滚边器配合使用,只要一道工序即可完成. 连续缝纫非常顺畅.喇叭尺寸如图表

Using 4 or 2 needle and special folder for shirt-fronting, only one sewing process is required. Size of folder as listed in the table below.

规格Spec 代号Code	完成尺寸 Finished Size	人布宽度 Tape Size	针距 Needle Gauge	机型 Model
B529	1-3/8"	2-3/8"	1/4 - 3/4 - 1/4"	VC008-0464-191P
B529P	1-1/2"	2-1/2"	3/16 - 1 - 3/16"	VC008-0448-254P
B529Q	1-5/8"	2-5/8"	1/4 - 1 - 1/4"	VC008-0464-254P

可自行组装 self-installation : YES

适用机型 applicable model : VC008-0448-254P, VC008-0464-191P,
VC008-0464-254P



VSM

花饰缝装置 Decorative Sewing

由16个花盘变化·利用针线之搭配,可缝制数十种不同花样·适用于高级衣饰、窗帘、床罩等寝具的装饰缝及桌巾或室内装饰品之花饰缝

Using sixteen different cams of variation for different sewing, suitable for decorative sewing on high quality dress, curtain, bedcover, table cloth or indoor decoration.

可自行组装 self-installation : NO

适用机型 applicable model : VC008-12048P, VC008-12064P



VSSM

花饰缝 Decorative Sewing

由16个花盘变化·利用针线之搭配,可缝製数十种不同花样·适用于高级衣饰、窗帘、床罩等寝具的装饰缝及桌巾或室内装饰品之花饰缝

To use sixteen different cams of variation for different sewing, suitable for decorative sewing on high quality dresses, curtains, bed sheets and tablecloths.

可自行组装 self-installation : NO

适用机型 applicable model : VC008-12048P, VC008-12064P



VSQ

松紧花饰缝装置 Decorative Sewing with Elastic Thread Shirring

由16个花盘变化，利用松紧针线之搭配，可缝制数十种不同花样，适用于高级衣饰、窗帘、床罩等寝具的装饰缝及桌巾或室内装饰品之花饰缝

Using sixteen different cams of variation for different sewing, suitable for decorative sewing on high quality dress, curtain, bedcover, table cloth or indoor decoration.

可自行组装 self-installation : YES

适用机型 applicable model : VC008-12048P, VC008-12064P

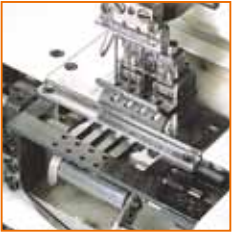

VUT

自动切线装置 Pneumatic Automatic Thread Trimmer

气动式自动切线可提高车缝效率节省成本

Pneumatic automatic thread trimmer increases operation efficiency and saves the cost.

可自行组装 self-installation : NO

适用机型 applicable model : VC008-04064P, VC008-04085P, VC008-04095P
VC008-04106P, VC008-04127P, VC008-12050P

MOTOR

代码 Motor No.		规格 Specification					适用机型 Applicable Model
		W	V	Pole	Phase	HZ / R.P.M.	
离合器马达 Clutch Motor	T3230Dx	400W	110	2	1	50HZ/2850 R.P.M. 60HZ/3450 R.P.M.	VC008 HF008 Z008
	T3201Dx		220				
	T3202Dx		240				
	T3203Dx		380				
	T3204Dx		220				
	T3231Dx	550W	110		1		
	T3205Dx		220				
	T3206Dx		240				
	T3207Dx		380		3		
	T3208Dx		220				
伺服马达 Servo Motor	T6424EH	750W	220-240	4	1	50HZ/60HZ 3500 R.P.M.	VC008 VC008/VUT
	T6425EH	550W			380		
	T7119CH		220-240			1	50HZ/60HZ 3000 R.P.M.
	TC201KH				380		
	TC202KH		220-240		3	Z008	
	TC301EH						

TABLE

桌板代号 ITEM NO.	尺寸 / SIZE(mm)			说明 Description	适用机型 Applicable Model	备注 Remark
	长 Length	宽 Width	厚 Thickness			
VC008-T1	1200	540	45	半沉式 Semi-submerged	VC008-04	
VC008-T2	1200	540	45	上乘式 Non-submerged	VC008-04	
VC008-T3	1200	540	45	半沉式 Semi-submerged	VC008-06/VPL VC008-12,13	
VC008-T4	1200	540	45	上乘式 Non-submerged		
VC008-T5	1200	540	45	半沉式 Semi-submerged	VC008-04/VWL VC008-04/VWLB VC008-04/VWLC	
VC008-T6	1200	540	45	半沉式 Semi-submerged	VC008-12/VPQK VC008-12/VWL VC008-12/VWLB VC008-12/VWLC VC008-12/VSSM VC008-12/VSC	
VC008-T7	1200	540	45	半沉式 Semi-submerged	VC008/VMR	
VC008-T8	1200	540	45	半沉式 Semi-submerged	VC008-12/VSM VC008-12/VSQ	
HF008-T1	1200	540	45	半沉式 Semi-submerged	HF008	
HF008-T4	1200	540	45	半沉式 Semi-submerged	HF008/FBQ	
Z008-T1	1200	540	45	半沉式 Semi-submerged	Z008	
Z008-T2	1200	540	45	上乘式 Non-submerged	Z008	